

# meusburger

SETTING STANDARDS

## H 1000

THE MULTIFUNCTIONAL CLAMPING  
SYSTEM FOR MOULD MAKING



# H 1000 FOR MOULD MAKING – FAST AND PRECISE CLAMPING WITH REPEATABLE ACCURACY

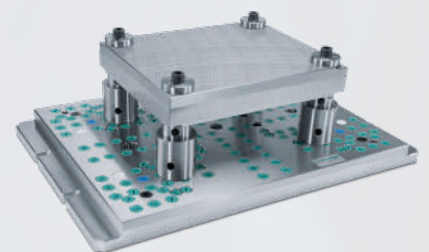
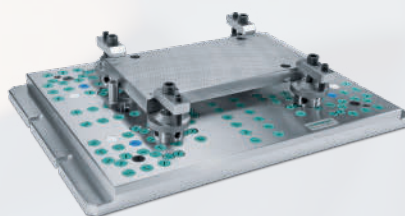
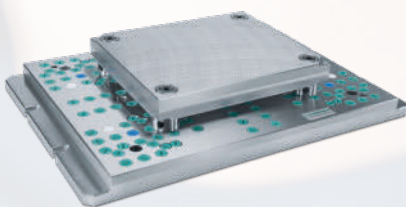

The H 1000 clamping system is an innovative in-house development by Meusburger. With the H 1000 you will not only work quickly and efficiently but also with absolute precision and repeatability. The standard F parts are aligned and clamped where it is important for the mould function, i.e. in the guide holes.

### YOU TOO CAN PROFIT FROM THE MANY BENEFITS OF THE H 1000

- » Improves the quality of your moulds by precise clamping in the  $\mu$ -range with repeatable accuracy
- » Reduce your processing time by substantially reducing fitting time
- » Minimise the risk of collision by using expansion rings for clamping
- » Use pallets for various special clamping tasks

Trust the original – **with over 2,000 pieces sold, Meusburger's clamping system** has been thoroughly tried and tested and is definitely a sophisticated product!



Technical Tips on the subject „H 1000“ at  
[www.meusburger.com/h1000-clamping](http://www.meusburger.com/h1000-clamping)

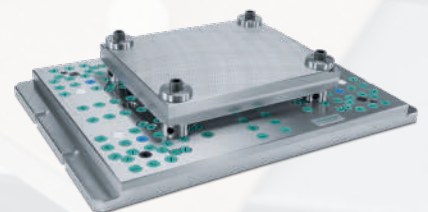
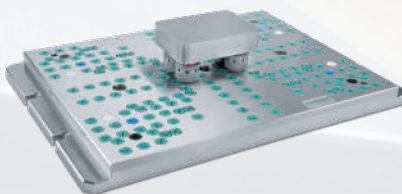
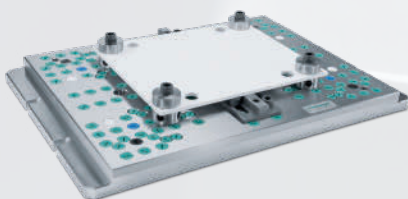

# H 1000 ASSISTENT – FOR SIMPLIFIED CONFIGURATION

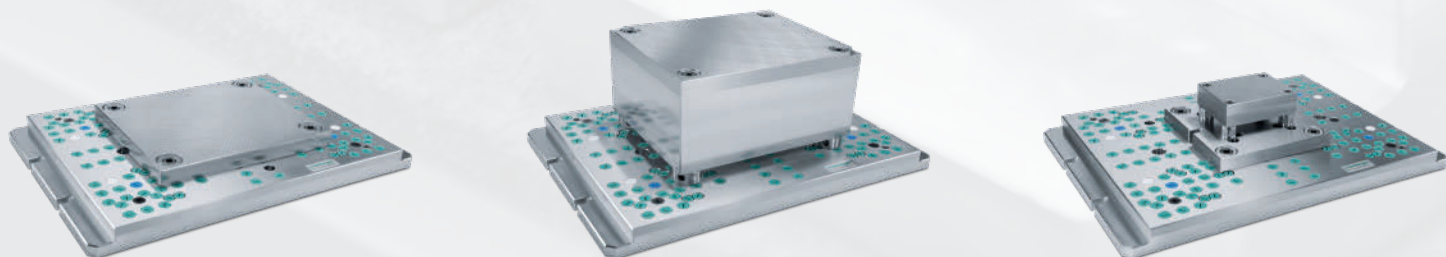
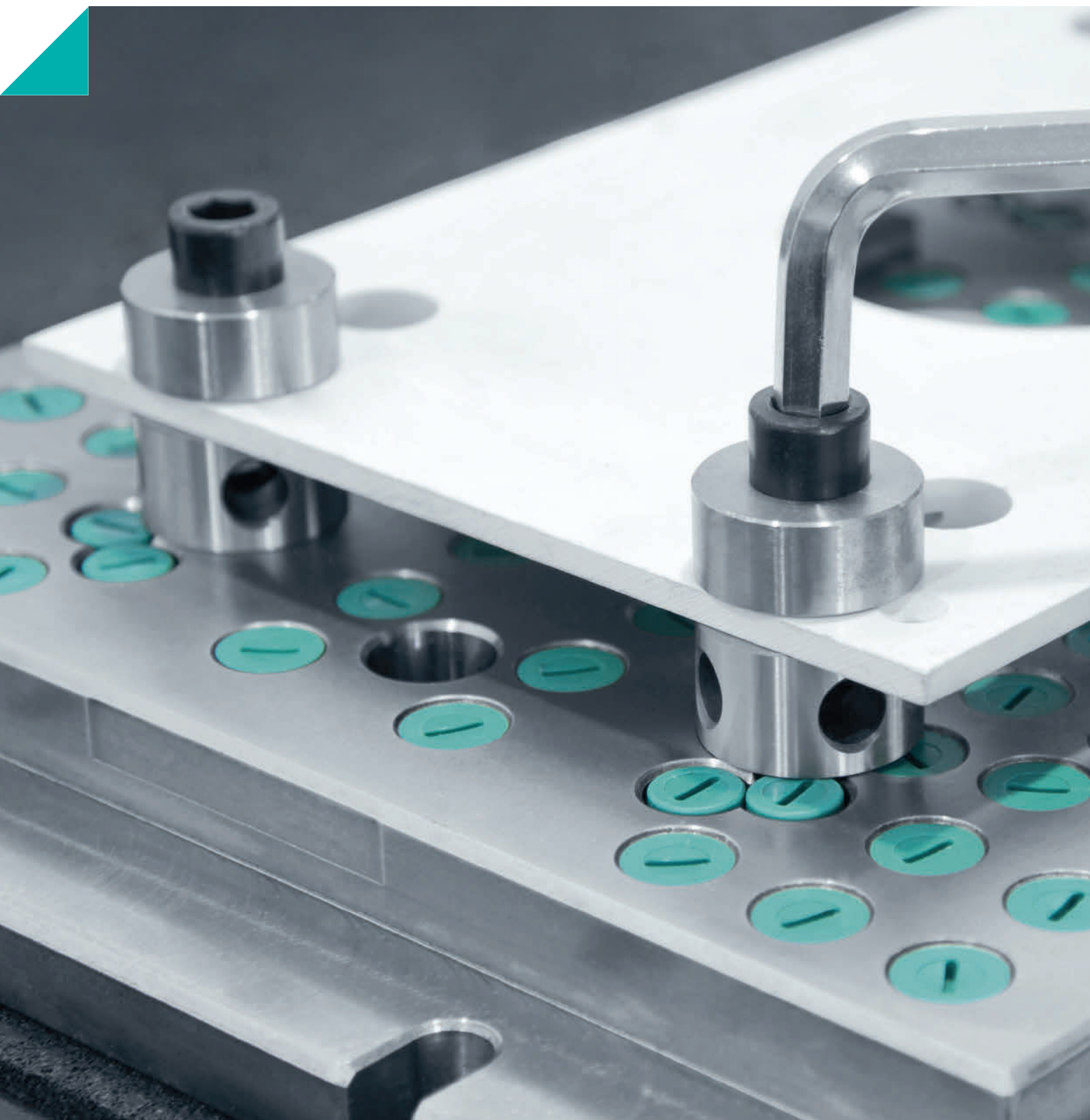

With our H 1000 Wizard you can quickly and easily configure your personal H 1000 Clamping system. First select the desired plate size and then simply put together the clamping elements necessary for your diameters for the cavity and ejector plates. The fully automatic calculation of required clamping elements ensures that you get the complete package. Optionally, additional packages for horizontal machining or pallets for clamping vices, electrode holders etc. are available.

### HOW YOU BENEFIT – AT A GLANCE:

- » Easy and quick configuration of the H 1000 clamping system
- » 6 different plate sizes offering various clamping options for cavity plates and ejector plates
- » Fully automatic calculation of required clamping elements

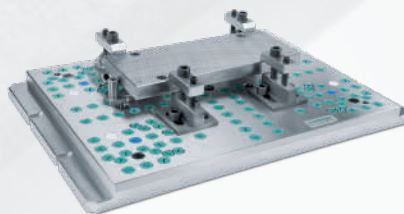
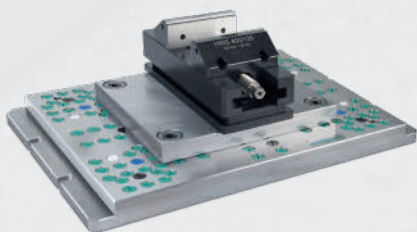
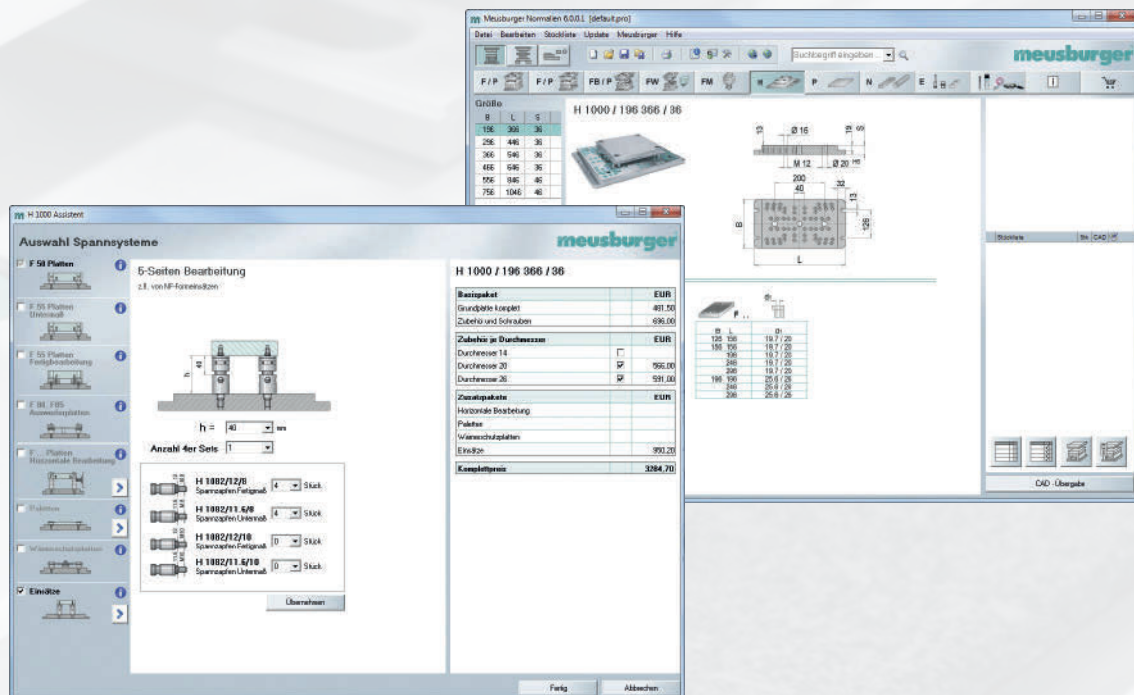

# H 1000 CLAMPING PLATE

## H 1000/196 366

### PRODUCT DESCRIPTION

» With 2 alignment edges for alignment on the machine

### MATERIAL

» 1.2312

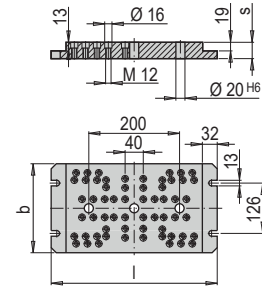

b	l	s	No.
196	366	36	H 1000/196 366/36/2312



Clamping options from page 14

H 1000 coordinates available at [www.meusburger.com/download](http://www.meusburger.com/download)

### MOULD SIZE

B	L	d1
126	156	19.7 / 20
156	156	19.7 / 20
156	196	19.7 / 20
156	246	19.7 / 20
156	296	19.7 / 20
196	196	25.6 / 26
196	246	25.6 / 26
196	296	25.6 / 26

# H 1000/296 446

## PRODUCT DESCRIPTION

» With 2 alignment edges for alignment on the machine

## MATERIAL

» 1.2312

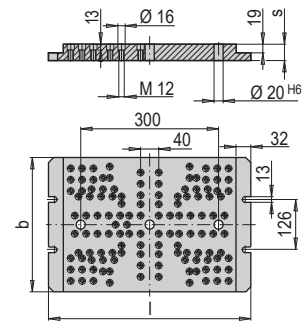

b	l	s	No.
296	446	36	H 1000/296 446/36/2312



Clamping options from page 14

H 1000 coordinates available at [www.meusburger.com/download](http://www.meusburger.com/download)

## MOULD SIZE

B	L	d1	B	L	d1
126	156	19.7 / 20	196	396	29.5 / 30
156	156	19.7 / 20	216	246	25.6 / 26
156	196	19.7 / 20	216	296	25.6 / 26
156	246	19.7 / 20	246	246	25.6 / 26
156	296	19.7 / 20	246	296	29.5 / 30
156	346	19.7 / 20	246	346	29.5 / 30
196	196	25.6 / 26	246	396	29.5 / 30
196	246	25.6 / 26	296	296	29.5 / 30
196	296	25.6 / 26	296	346	29.5 / 30
196	346	29.5 / 30	296	396	29.5 / 30

# H 1000/366 546

## PRODUCT DESCRIPTION

» With 2 alignment edges for alignment on the machine

## MATERIAL

» 1.2312

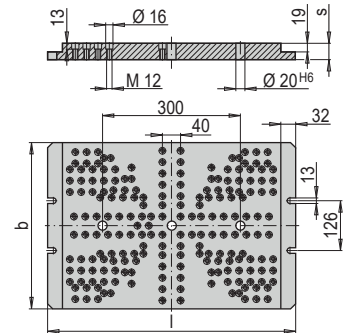









b	l	s	No.
366	546	36	H 1000/366 546/36/2312



Clamping options from page 14

H 1000 coordinates available at [www.meusburger.com/download](http://www.meusburger.com/download)

## MOULD SIZE

							
B L	d1	B L	d1	B L	d1	B L	d1
126 156	19.7 / 20	196 396	29.5 / 30	246 496	29.5 / 30	346 496	41.4 / 42
156 156	19.7 / 20	196 446	29.5 / 30	296 296	29.5 / 30	396 396	41.4 / 42
156 196	19.7 / 20	196 496	29.5 / 30	296 346	29.5 / 30	396 446	41.4 / 42
156 246	19.7 / 20	216 246	25.6 / 26	296 396	29.5 / 30	396 496	41.4 / 42
156 296	19.7 / 20	216 296	25.6 / 26	296 446	29.5 / 30		
156 346	19.7 / 20	246 246	25.6 / 26	296 496	29.5 / 30		
196 196	25.6 / 26	246 296	29.5 / 30	316 346	29.5 / 30		
196 246	25.6 / 26	246 346	29.5 / 30	346 346	29.5 / 30		
196 296	25.6 / 26	246 396	29.5 / 30	346 396	41.4 / 42		
196 346	29.5 / 30	246 446	29.5 / 30	346 446	41.4 / 42		



# H 1000/466 646

## PRODUCT DESCRIPTION

» With 2 alignment edges for alignment on the machine

## MATERIAL

» 1.2312

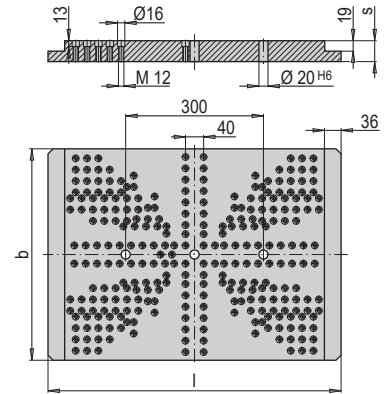









b	l	s	No.
466	646	36	H 1000/466 646/36/2312



Clamping options from page 14

H 1000 coordinates available at [www.meusburger.com/download](http://www.meusburger.com/download)

## MOULD SIZE

 B L	 d1	 B L	 d1	 B L	 d1	 B L	 d1
126 156	19.7 / 20	216 296	25.6 / 26	296 546	29.5 / 30	396 596	41.4 / 42
156 156	19.7 / 20	246 246	25.6 / 26	296 596	29.5 / 30	446 446	41.4 / 42
156 196	19.7 / 20	246 296	29.5 / 30	316 346	29.5 / 30	446 496	41.4 / 42
156 246	19.7 / 20	246 346	29.5 / 30	316 396	29.5 / 30	446 546	41.4 / 42
156 296	19.7 / 20	246 396	29.5 / 30	346 346	29.5 / 30	446 596	41.4 / 42
156 346	19.7 / 20	246 446	29.5 / 30	346 396	41.4 / 42	496 496	41.4 / 42
196 196	25.6 / 26	246 496	29.5 / 30	346 446	41.4 / 42	496 546	41.4 / 42
196 246	25.6 / 26	246 546	29.5 / 30	346 496	41.4 / 42	496 596	41.4 / 42
196 296	25.6 / 26	246 596	29.5 / 30	346 546	41.4 / 42		
196 346	29.5 / 30	296 296	29.5 / 30	346 596	41.4 / 42		
196 396	29.5 / 30	296 346	29.5 / 30	396 396	41.4 / 42		
196 446	29.5 / 30	296 396	29.5 / 30	396 446	41.4 / 42		
196 496	29.5 / 30	296 446	29.5 / 30	396 496	41.4 / 42		
216 246	25.6 / 26	296 496	29.5 / 30	396 546	41.4 / 42		

# H 1000/556 846

## PRODUCT DESCRIPTION

» With 2 alignment edges for alignment on the machine

## MATERIAL

» 1.2312

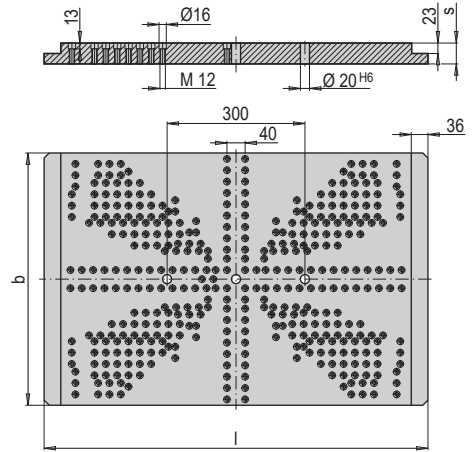









b	l	s	No.
556	846	46	H 1000/556 846/46/2312



Clamping options from page 14

H 1000 coordinates available at [www.meusburger.com/download](http://www.meusburger.com/download)

## MOULD SIZE

							
B L	d1	B L	d1	B L	d1	B L	d1
126 156	19.7 / 20	246 496	29.5 / 30	346 646	41.4 / 42	496 596	41.4 / 42
156 156	19.7 / 20	246 546	29.5 / 30	346 696	41.4 / 42	496 646	41.4 / 42
156 196	19.7 / 20	246 596	29.5 / 30	346 796	41.4 / 42	496 696	41.4 / 42
156 246	19.7 / 20	296 296	29.5 / 30	396 396	41.4 / 42	496 796	53.3 / 54
156 296	19.7 / 20	296 346	29.5 / 30	396 446	41.4 / 42	546 546	41.4 / 42
156 346	19.7 / 20	296 396	29.5 / 30	396 496	41.4 / 42	546 596	53.3 / 54
196 196	25.6 / 26	296 446	29.5 / 30	396 546	41.4 / 42	546 646	53.3 / 54
196 246	25.6 / 26	296 496	29.5 / 30	396 596	41.4 / 42	546 696	53.3 / 54
196 296	25.6 / 26	296 546	29.5 / 30	396 646	41.4 / 42	546 796	53.3 / 54
196 346	29.5 / 30	296 596	29.5 / 30	396 696	41.4 / 42	596 596	53.3 / 54
196 396	29.5 / 30	296 646	29.5 / 30	396 796	41.4 / 42	596 646	53.3 / 54
196 446	29.5 / 30	296 696	29.5 / 30	446 446	41.4 / 42	596 696	53.3 / 54
196 496	29.5 / 30	316 346	29.5 / 30	446 496	41.4 / 42	596 796	53.3 / 54
216 246	25.6 / 26	316 396	29.5 / 30	446 546	41.4 / 42		
216 296	25.6 / 26	346 346	29.5 / 30	446 596	41.4 / 42		
246 246	25.6 / 26	346 396	41.4 / 42	446 646	41.4 / 42		
246 296	29.5 / 30	346 446	41.4 / 42	446 696	41.4 / 42		
246 346	29.5 / 30	346 496	41.4 / 42	446 796	41.4 / 42		
246 396	29.5 / 30	346 546	41.4 / 42	496 496	41.4 / 42		
246 446	29.5 / 30	346 596	41.4 / 42	496 546	41.4 / 42		

# H 1000/756 1046

## PRODUCT DESCRIPTION

» With 2 alignment edges for alignment on the machine

## MATERIAL

» 1.2312

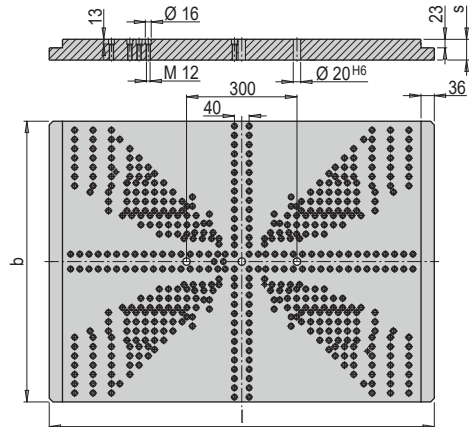













b	l	s	No.
756	1046	46	H 1000/756 1046/46/2312



Clamping options from page 14

H 1000 coordinates available at [www.meusburger.com/download](http://www.meusburger.com/download)

## MOULD SIZE

 B L	 d1	 B L	 d1	 B L	 d1	 B L	 d1	 B L	 d1	 B L	 d1
126 156	19.7 / 20	246 296	29.5 / 30	316 346	29.5 / 30	396 646	41.4 / 42	496 796	53.3 / 54	646 646	53.3 / 54
156 156	19.7 / 20	246 346	29.5 / 30	316 396	29.5 / 30	396 696	41.4 / 42	496 896	53.3 / 54	646 696	53.3 / 54
156 196	19.7 / 20	246 396	29.5 / 30	346 346	29.5 / 30	396 796	41.4 / 42	496 996	53.3 / 54	646 796	53.3 / 54
156 246	19.7 / 20	246 446	29.5 / 30	346 396	41.4 / 42	446 446	41.4 / 42	546 546	41.4 / 42	646 896	53.3 / 54
156 296	19.7 / 20	246 496	29.5 / 30	346 446	41.4 / 42	446 496	41.4 / 42	546 596	53.3 / 54	646 996	53.3 / 54
156 346	19.7 / 20	246 546	29.5 / 30	346 496	41.4 / 42	446 546	41.4 / 42	546 646	53.3 / 54	696 696	53.3 / 54
196 196	25.6 / 26	246 596	29.5 / 30	346 546	41.4 / 42	446 596	41.4 / 42	546 696	53.3 / 54	696 796	53.3 / 54
196 246	25.6 / 26	296 296	29.5 / 30	346 596	41.4 / 42	446 646	41.4 / 42	546 796	53.3 / 54	696 896	53.3 / 54
196 296	25.6 / 26	296 346	29.5 / 30	346 646	41.4 / 42	446 696	41.4 / 42	546 896	53.3 / 54	696 996	53.3 / 54
196 346	29.5 / 30	296 396	29.5 / 30	346 696	41.4 / 42	446 796	41.4 / 42	546 996	53.3 / 54	746 746	53.3 / 54
196 396	29.5 / 30	296 446	29.5 / 30	346 796	41.4 / 42	446 896	41.4 / 42	596 596	53.3 / 54	746 796	53.3 / 54
196 446	29.5 / 30	296 496	29.5 / 30	396 396	41.4 / 42	496 496	41.4 / 42	596 646	53.3 / 54	746 896	53.3 / 54
196 496	29.5 / 30	296 546	29.5 / 30	396 446	41.4 / 42	496 546	41.4 / 42	596 696	53.3 / 54	746 996	53.3 / 54
216 246	25.6 / 26	296 596	29.5 / 30	396 496	41.4 / 42	496 596	41.4 / 42	596 796	53.3 / 54	796 796	53.3 / 54
216 296	25.6 / 26	296 646	29.5 / 30	396 546	41.4 / 42	496 646	41.4 / 42	596 896	53.3 / 54	796 896	53.3 / 54
246 246	25.6 / 26	296 696	29.5 / 30	396 596	41.4 / 42	496 696	41.4 / 42	596 996	53.3 / 54	796 996	53.3 / 54

# CLAMPING PLATE WITH 20 MM GRID

## H 20100/196 366

### PRODUCT DESCRIPTION

» With 2 alignment edges for alignment on the machine

### MATERIAL

» 1.2312

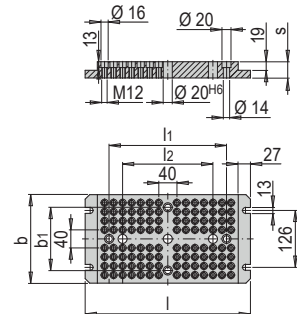

b1	l1	l2	b	l	s	No.
140	260	200	196	366	36	H 20100/196 366/36/2312



Clamping options from page 22

H 20100 coordinates available at [www.meusburger.com/download](http://www.meusburger.com/download)

## H 20100/296 446

### PRODUCT DESCRIPTION

» With 2 alignment edges for alignment on the machine

### MATERIAL

» 1.2312

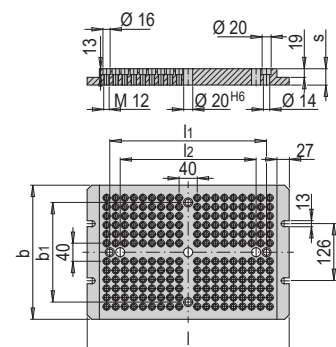

b1	l1	l2	b	l	s	No.
220	346	300	296	446	36	H 20100/296 446/36/2312



Clamping options from page 22

H 20100 coordinates available at [www.meusburger.com/download](http://www.meusburger.com/download)



# H 1000 CLAMPING OPTIONS

## CLAMPING OF F – PLATES WITH EXPANSION RINGS

### APPLICATION INFORMATION

» Enables clamping without obstructive contours to reduce the risk of collision.



H 1000 coordinates available at [www.meusburger.com/download](http://www.meusburger.com/download)

 d1	F .. / ... ..
d1	S min <sup>1)</sup>
13.8 / 14	17
19.7 / 20	34
25.6 / 26	34
29.5 / 30	34
41.4 / 42	38
53.3 / 54	38

<sup>1)</sup> Thin plates fixed with H 1024

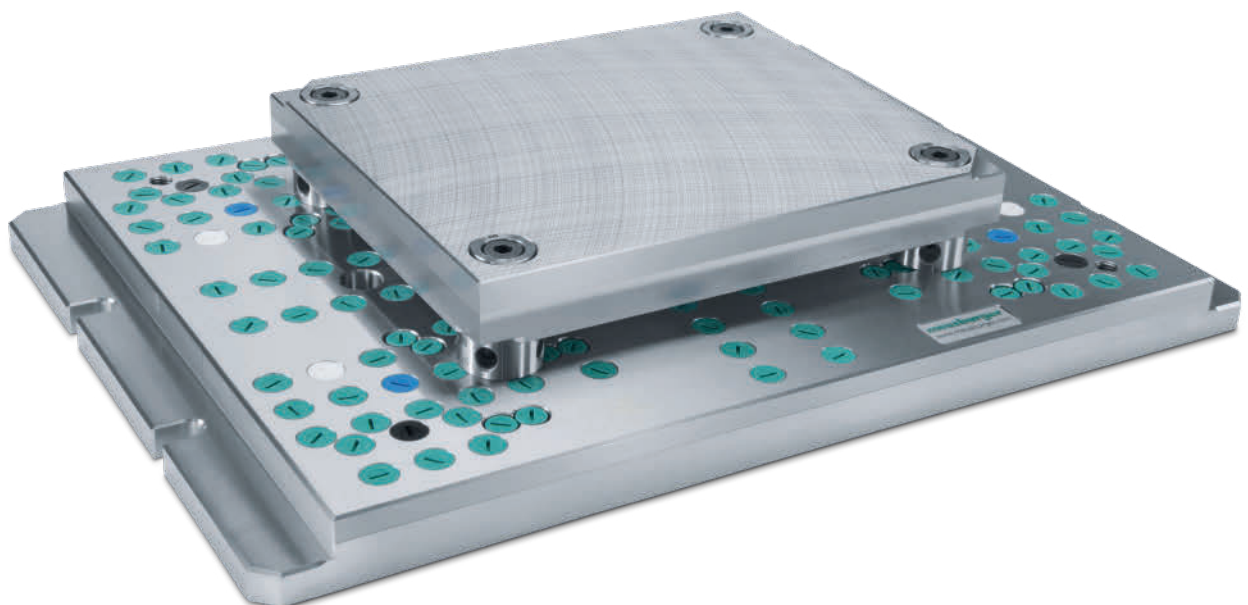
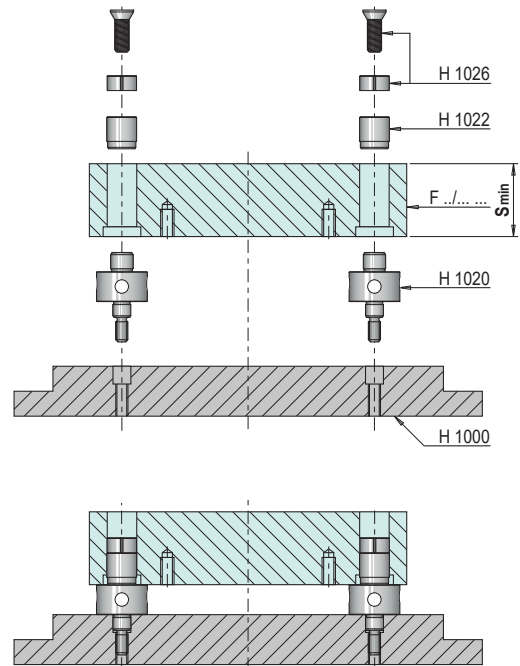

# CLAMPING OF F – PLATES WITH WASHERS

## APPLICATION INFORMATION

» The H 1024 washers are perfect for clamping thin plates.



H 1000 coordinates available at [www.meusburger.com/download](http://www.meusburger.com/download)

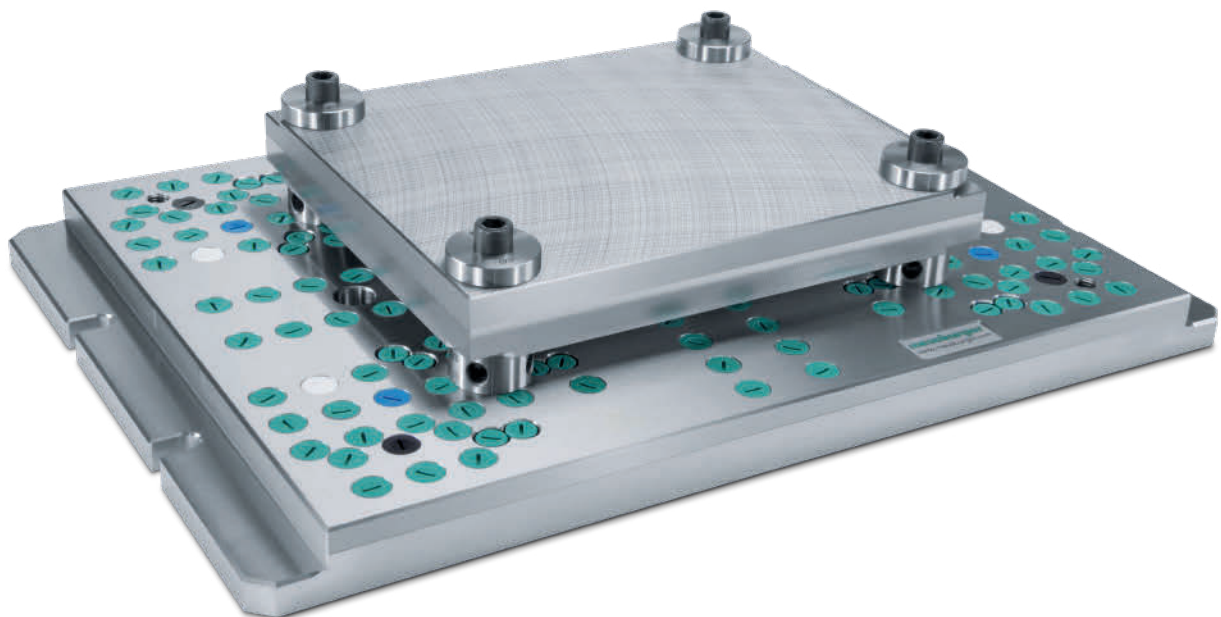
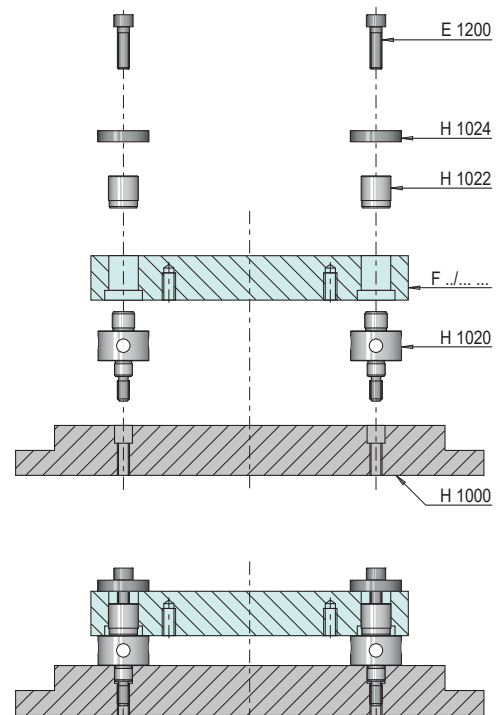

# CLAMPING OF F – PLATES WITH GUIDE DIAMETER 14

## APPLICATION INFORMATION

» F-Plates with diameter 14 are reliably clamped with the H 1088 pallet



H 1000 coordinates available at [www.meusburger.com/download](http://www.meusburger.com/download)

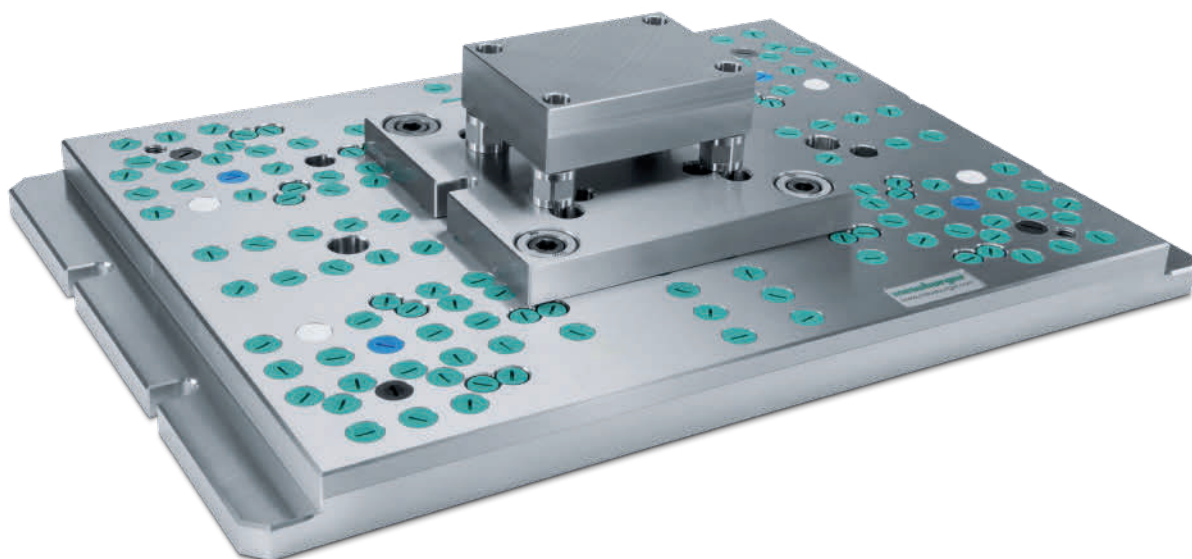
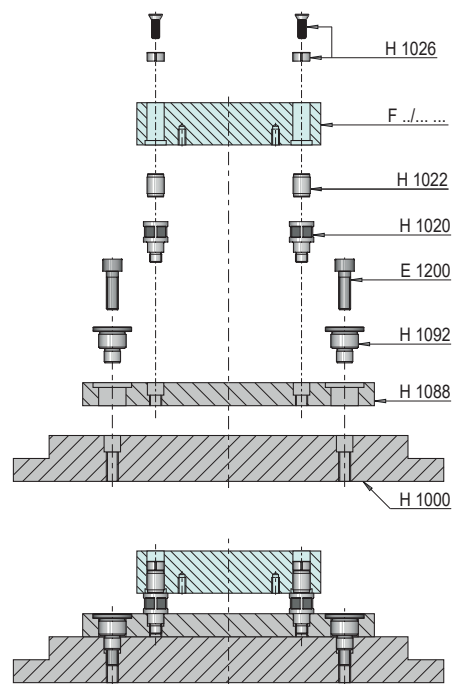



# CLAMPING OF F 55 PLATES

## APPLICATION INFORMATION

» Machine the guide diameters and the cavities in one clamping with the H 1070 Clamping blocks.



H 1000 coordinates available at [www.meusburger.com/download](http://www.meusburger.com/download)

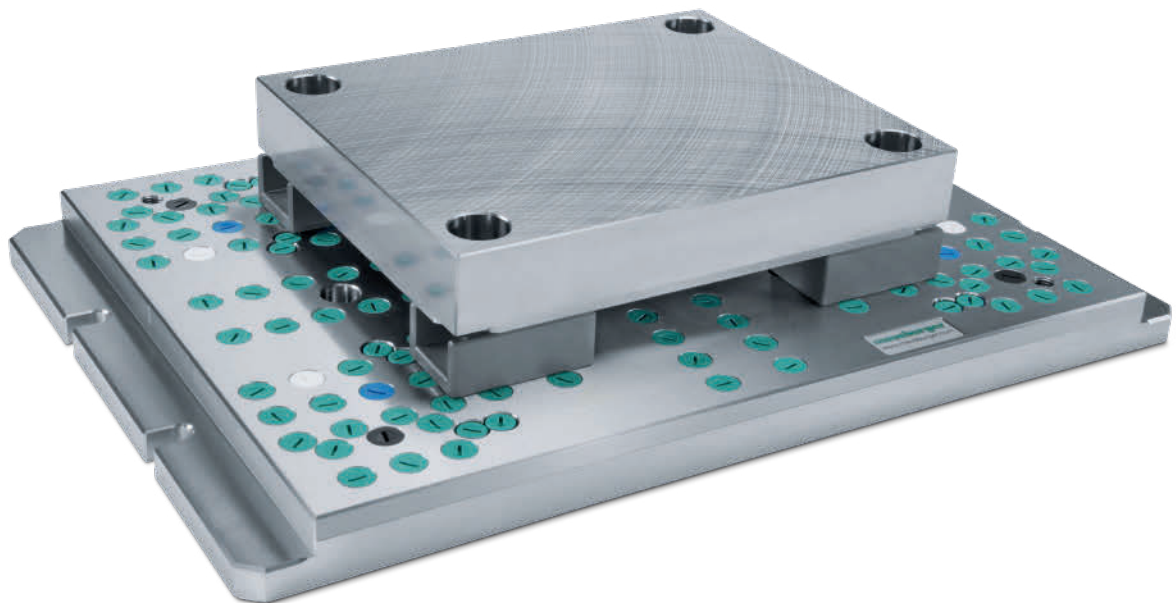
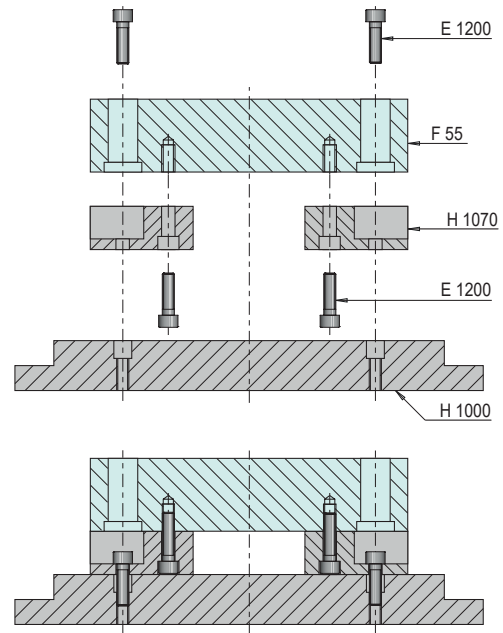

# CLAMPING OF F – PLATES FOR HORIZONTAL MACHINING

## APPLICATION INFORMATION

» Use the H 1030 Centring support extension pieces for 5-axis machining.



H 1000 coordinates available at [www.meusburger.com/download](http://www.meusburger.com/download)

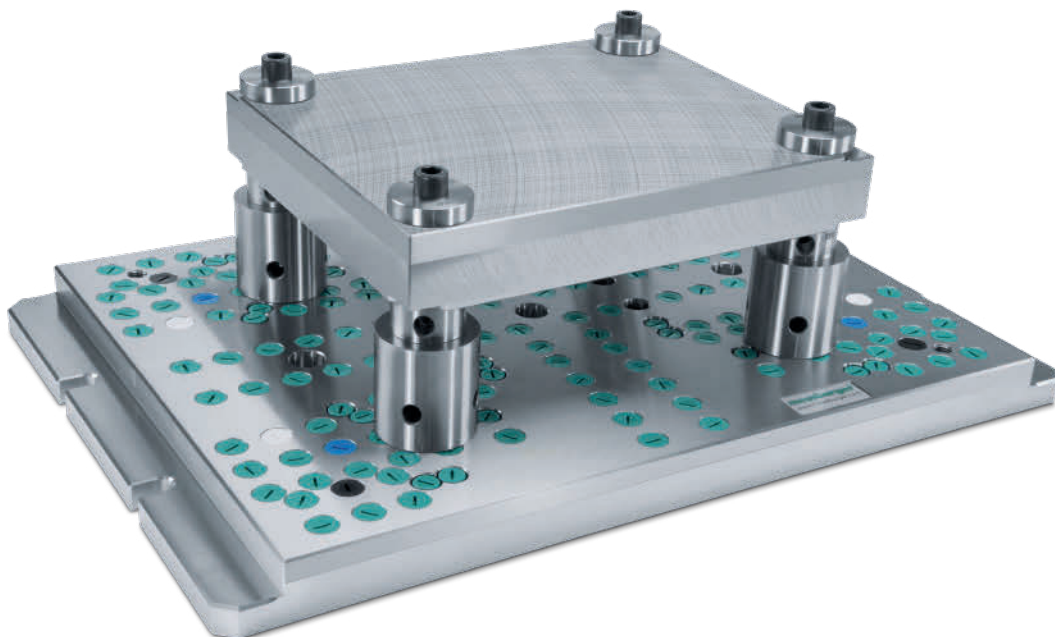
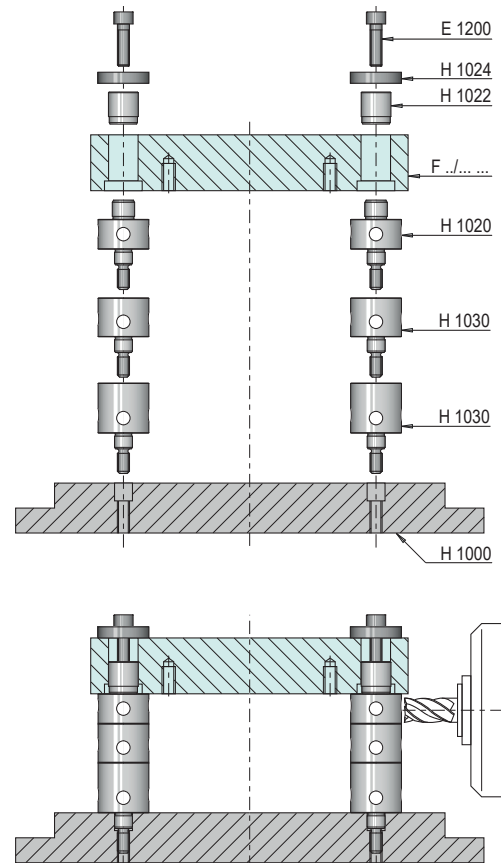

# CLAMPING OF F – PLATES WITH CLEARED BORE HOLES

## APPLICATION INFORMATION

» Use the H 1023<sup>1)</sup> clamping for thick plates with cleared bore holes.



H 1000 coordinates available at [www.meusburger.com/download](http://www.meusburger.com/download)

 d1	F .. / ... ..
d1	S > <sup>1)</sup>
30	156
42	196
54	216

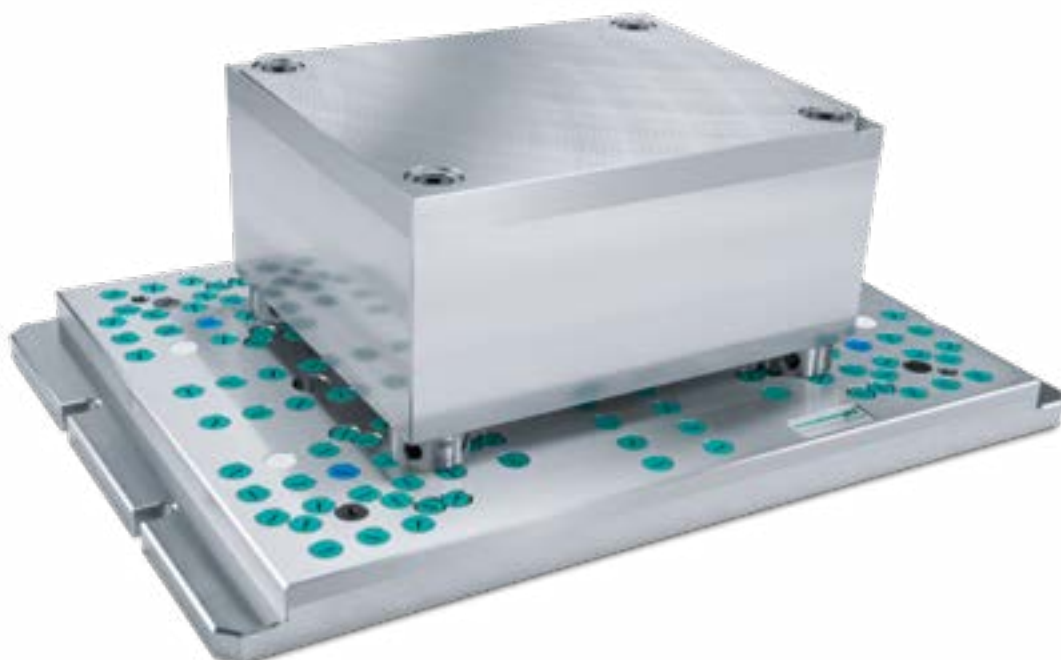
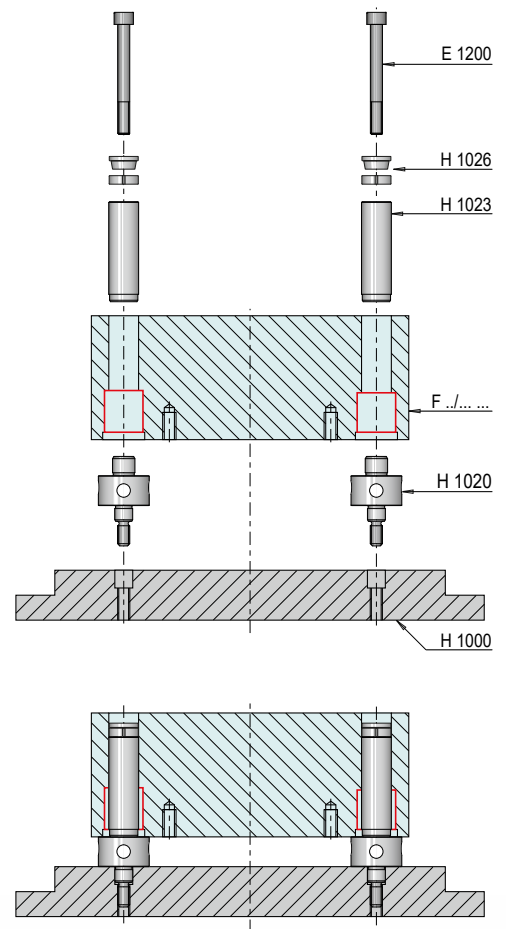

# CLAMPING OF WIDE EJECTOR PLATES

## APPLICATION INFORMATION

» Clamp ejector plates quickly to centre, without having to displace the centring supports.

 H 1000 coordinates available at [www.meusburger.com/download](http://www.meusburger.com/download)

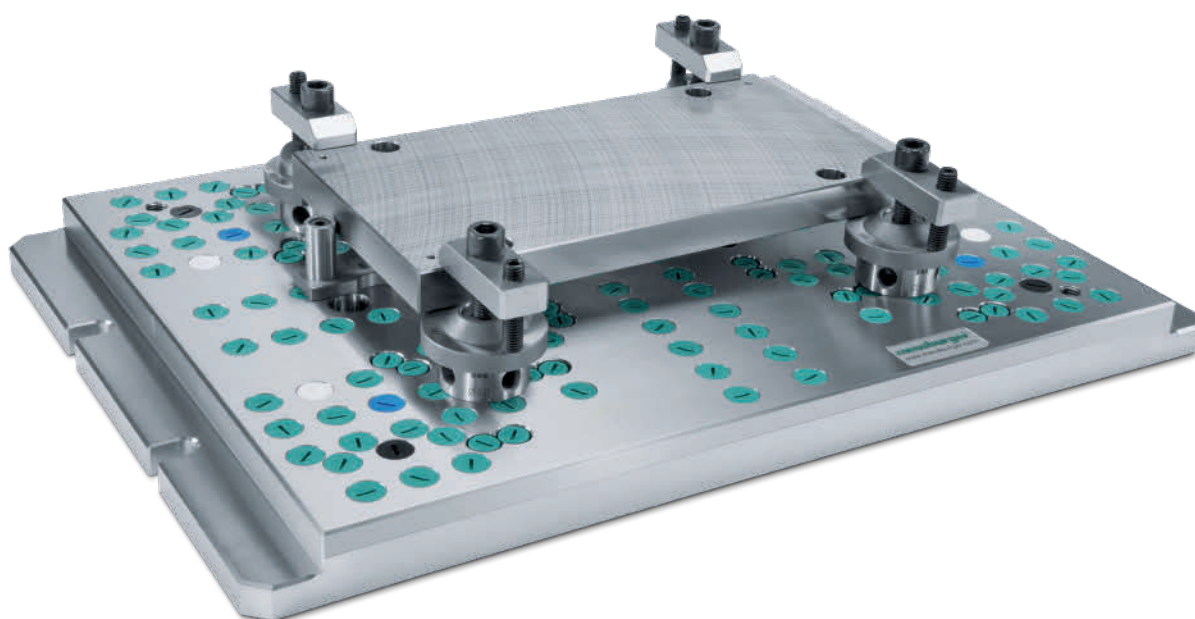
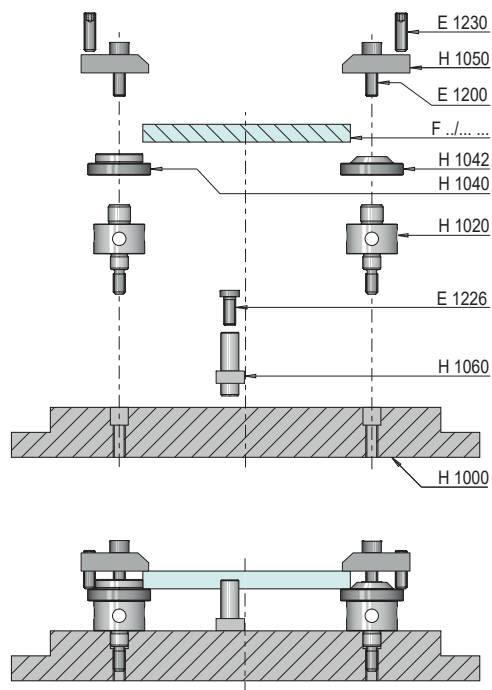

# CLAMPING OF NARROW EJECTOR PLATES

## APPLICATION INFORMATION

» Use the H 1062 for clamping narrow ejector plates.

 H 1000 coordinates available at [www.meusburger.com/download](http://www.meusburger.com/download)

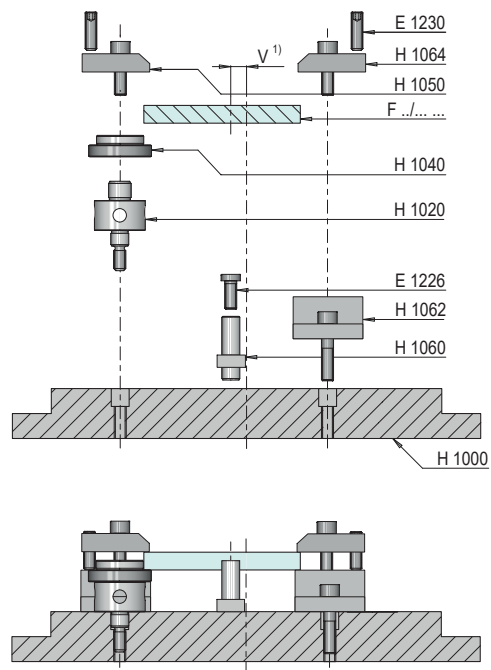

1) Offset to the centre

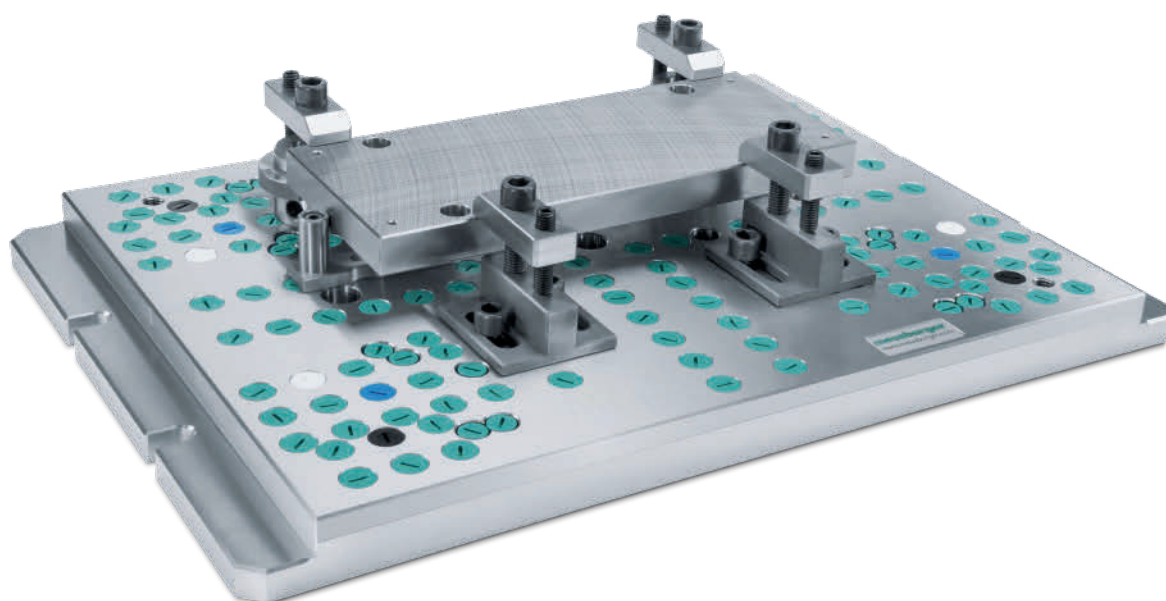

# CLAMPING OF NF - INSERTS

## APPLICATION INFORMATION

» Use the H 1030 Centring support extension pieces for 5-axis machining.



H 1000 coordinates available at [www.meusburger.com/download](http://www.meusburger.com/download)

d2	t2	d1	AM <sup>1)</sup>
M 8	12	11,6	30
M 8	12	12	30
M10	14	11,6	50
M10	14	12	50

1) AM: max. tightening torque [Nm] H 1082

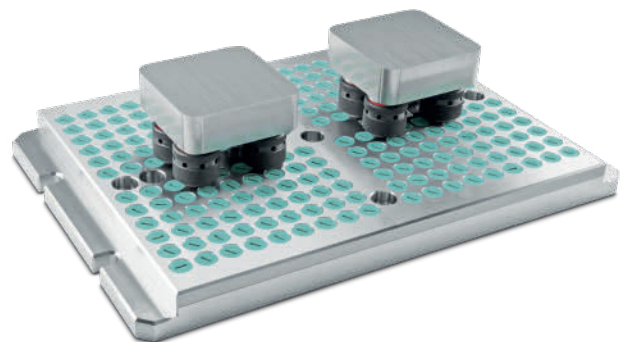
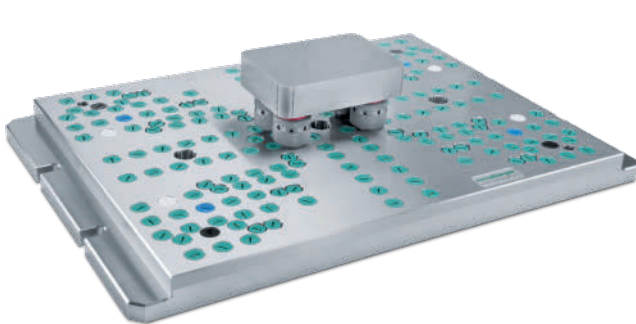
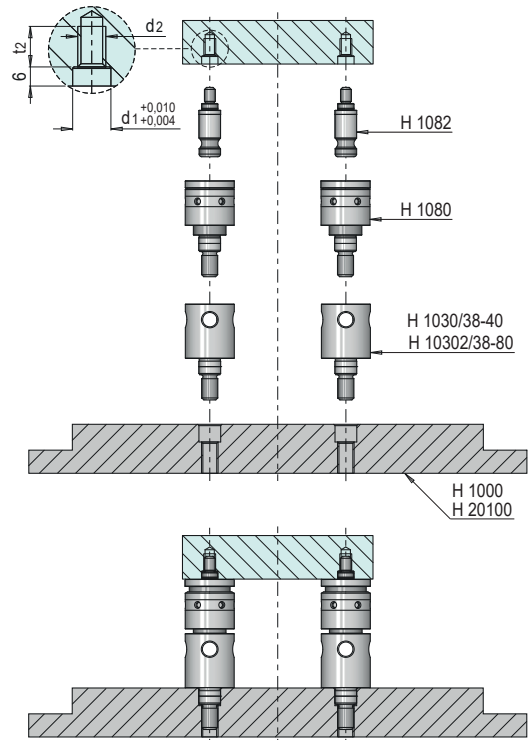

Technical Tips on the subject „Clamping of NF inserts“ at [www.meusburger.com/clamping-NF](http://www.meusburger.com/clamping-NF)

# CLAMPING OF INSULATION BOARDS

## APPLICATION INFORMATION

» Insulation boards can be reliably clamped with H 1048.



H 1000 coordinates available at [www.meusburger.com/download](http://www.meusburger.com/download)

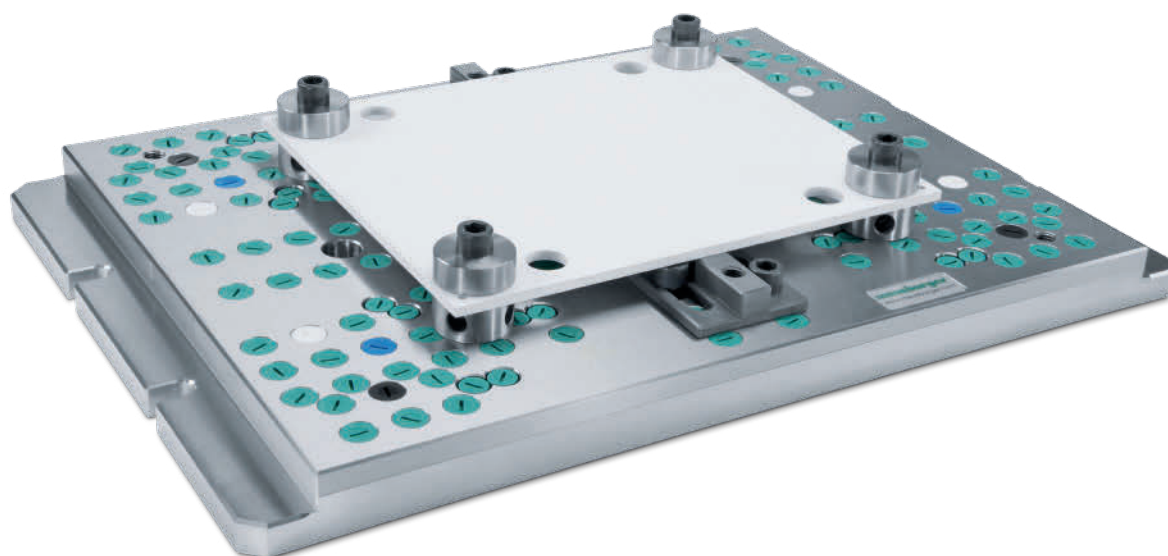
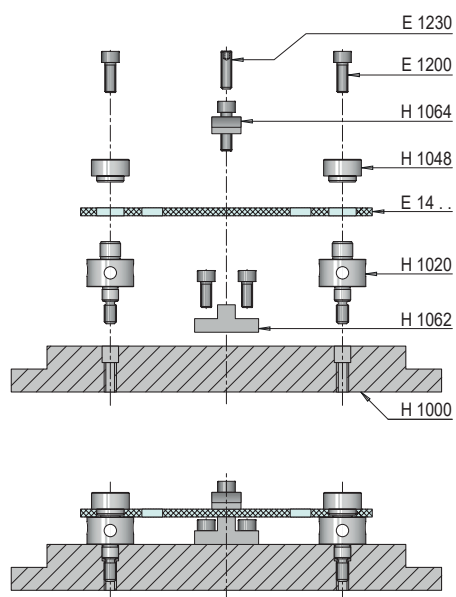

# CLAMPING OF PALLETS

## APPLICATION INFORMATION

» Clamp vices, electrode holders, etc. with the H 1090 Pallets.



H 1000 coordinates available at [www.meusburger.com/download](http://www.meusburger.com/download)

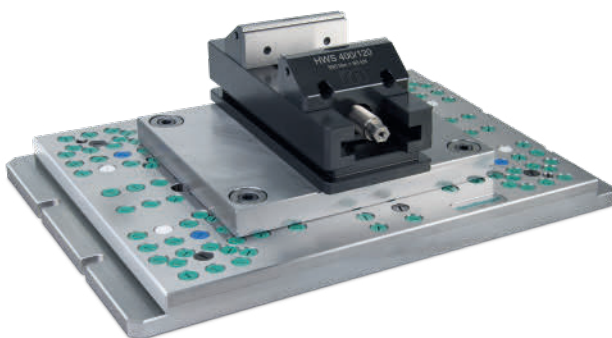
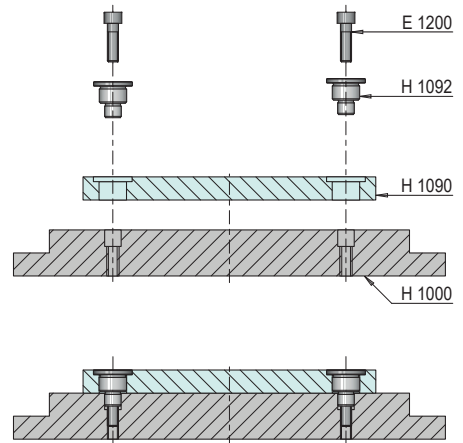
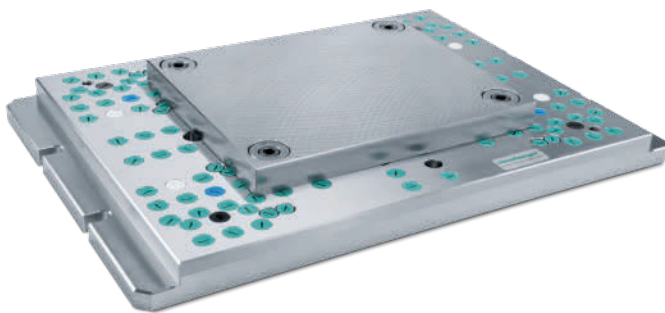

Application example: **vice**

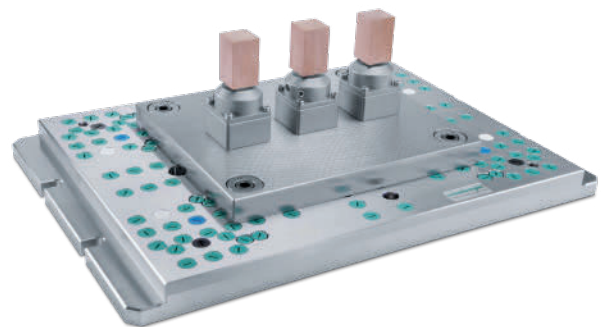

Application example: **electrode holder**





## CUSTOMER-SPECIFIC CLAMPING SYSTEMS

We manufacture customised clamping systems with H 1000 hole pattern. They enable maximum utilisation of the machine's pathways. The integration of a zero-point clamping system is also possible. All clamping systems, even in special sizes, with rounded edges or in round version, are compatible with the original H 1000 accessories.

### ROUND VERSION

» Optimally adjusted on your machine table



### FOR ZERO-POINT CLAMPING SYSTEMS

» Perfectly adapted for your zero-point clamping system

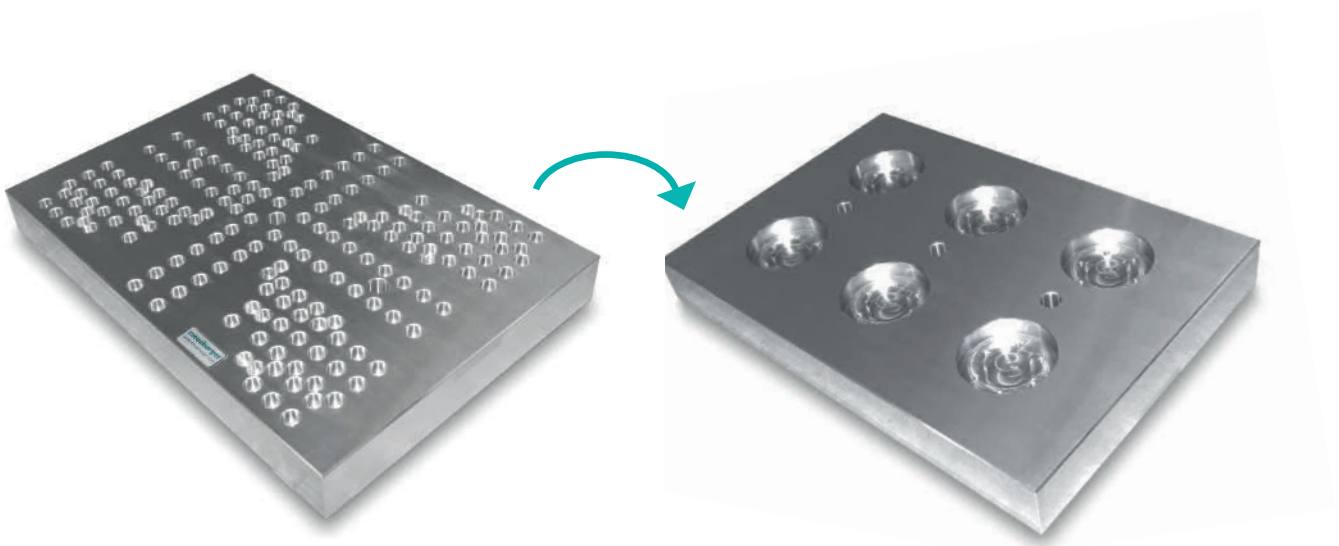



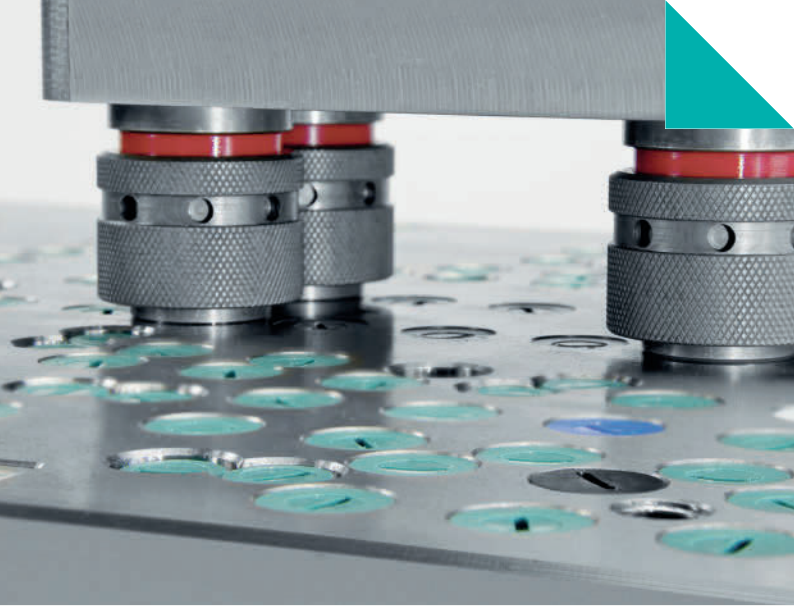

CONSISTENT  
HIGH QUALITY



REDUCED PLATE  
WARPING DURING  
MACHINING



OUTSTANDING  
SERVICE



CONTINUOUS  
AVAILABILITY



SHORT  
LEAD TIMES

## ORDERING – THE WAY YOU LIKE IT BEST!

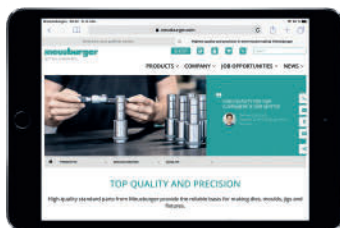
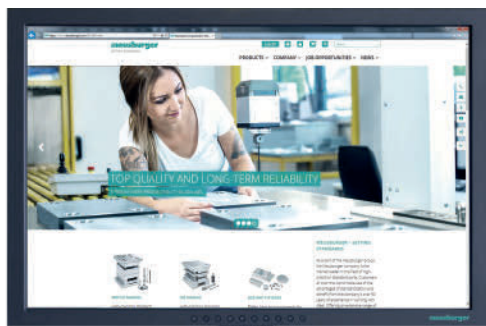

**Web shop**  
[www.meusburger.com](http://www.meusburger.com)



**Offline shop**  
install and get started!



**Phone**  
+43 5574 6706-0



**Email**  
[sales@meusburger.com](mailto:sales@meusburger.com)

©2019/1 Meusburger Georg GmbH & Co KG. All rights reserved. Any use, including but not limited to publication, copying, distribution, reproduction and/or modification, even in part, is prohibited without prior written authorisation of Meusburger Georg GmbH & Co KG. Technical changes and printing or other errors reserved.

X14068-V1-02/19-EN